

Centre Number	Candidate Number	Name
---------------	------------------	------

UNIVERSITY OF CAMBRIDGE INTERNATIONAL EXAMINATIONS
International General Certificate of Secondary Education

DESIGN AND TECHNOLOGY

0445/04

Paper 4 Systems and Control

Specimen Paper 2007

Candidates answer on the Question Paper.
No additional materials are required.

1 hour

To be taken together with Paper 1 in one session of 2 hours 15 minutes.

READ THESE INSTRUCTIONS FIRST

Write your Centre number, Candidate number and Name in the spaces at the top of this page.
Write in dark blue or black pen in the spaces provided on the Question Paper.
You may use a soft pencil for any diagrams, graphs or rough working.
Do not use staples, paper clips, highlighters, glue or correction fluid.

Section A

Answer **all** questions in this section.

Section B

Answer **one** question in this section.

The total of the marks for this paper is 50.
The number of marks is given in brackets [] at the end of each question or part question.
You may use a calculator.

For Examiner's use	
Section A	
Section B	
Total	

This document consists of **14** printed pages.



Section A

Answer **all** questions in this section.

1 Fig. 1 shows a beam under load.

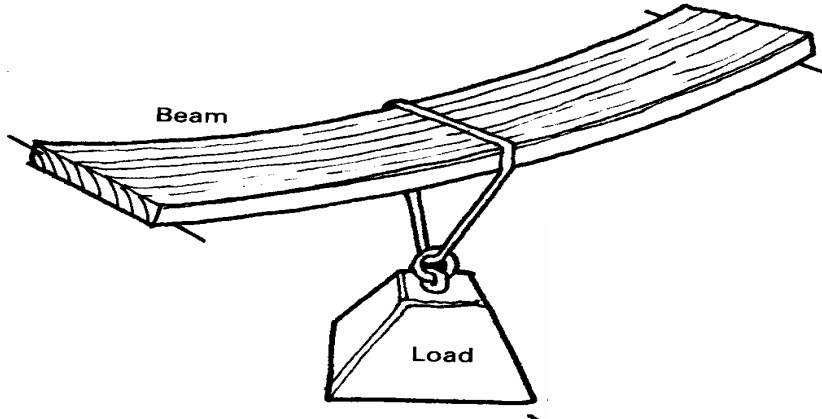

Fig. 1

Add labels to Fig. 1 to show clearly:

- tension forces
- compression forces.

[2]

2 Complete the diagram below to show the energy conversions that take place when a torch is switched on.

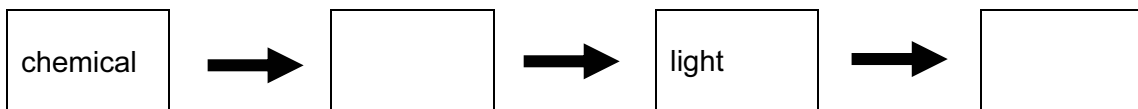

[2]

3 State **one** advantage of chain and sprocket transmission over belt and pulley transmission.

..... [1]

4 Give **one** example of a natural structure.

..... [1]

5 Fig. 2 shows two different gear systems.

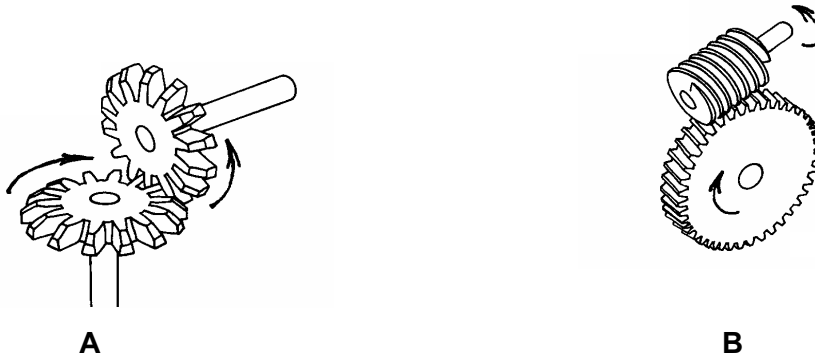

Fig. 2

(a) Name each gear system.

A [1]

B [1]

(b) Explain the effect of both of these systems on the direction of motion transmitted.

..... [1]

6 Fig. 3 shows a circuit for a fuse tester.

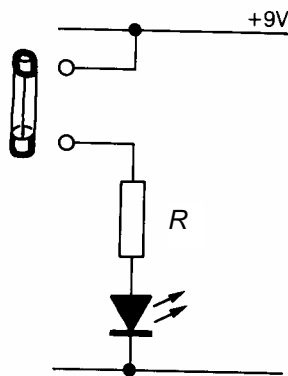

Fig.3

If the LED has a voltage of 2 V across it and a current of 0.01 A flowing through it calculate the value of R.

7 Use sketches and labels to show how a gusset plate can be used to reinforce a joint in a framework.

[2]

8 Name **two** types of motion **other than** rotary and reciprocating.

1

[1]

2

[1]

9 Give **one** reason why plastics are good materials for making casings for electronic circuits.

.....

..... [1]

10 The diagrams below show two different orders of lever.
Give the order and a use for each lever.

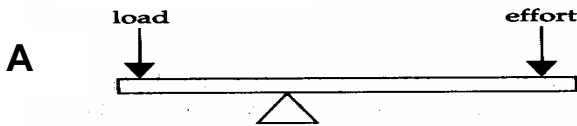

Order: [1]

Use: [1]

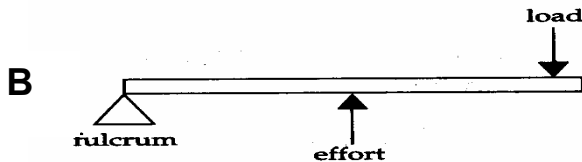

Order: [1]

Use: [1]

11 Fig. 4 shows a building.

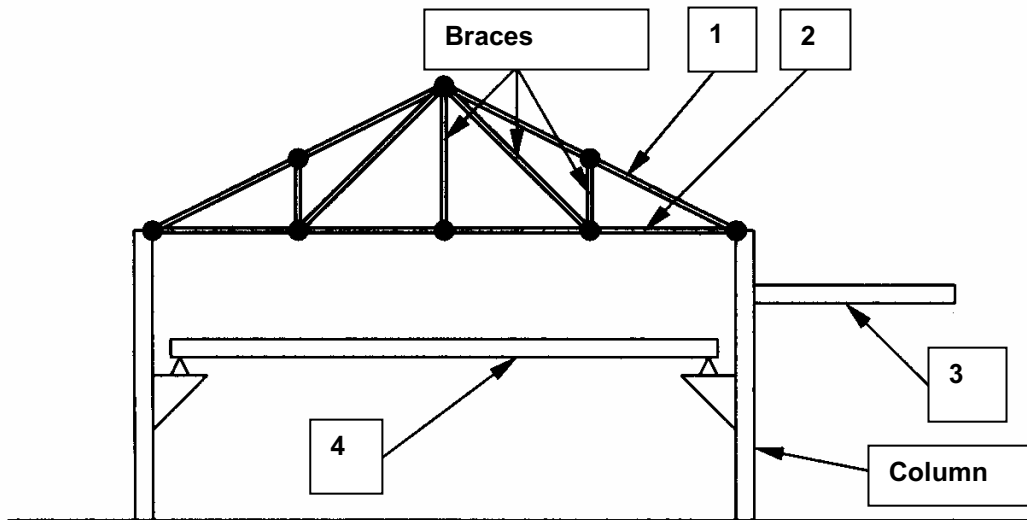

Fig. 4

Match the numbers from the diagram to the building components listed below.

Number from diagram	Building component
	Cantilever beam
	Tie (Member in tension)
	Strut (Member in compression)
	Simply supported beam

[4]

Section B

Answer **one** question in this section.

12 Fig. 5 shows a 555 timer circuit used in the construction of a kitchen timer.

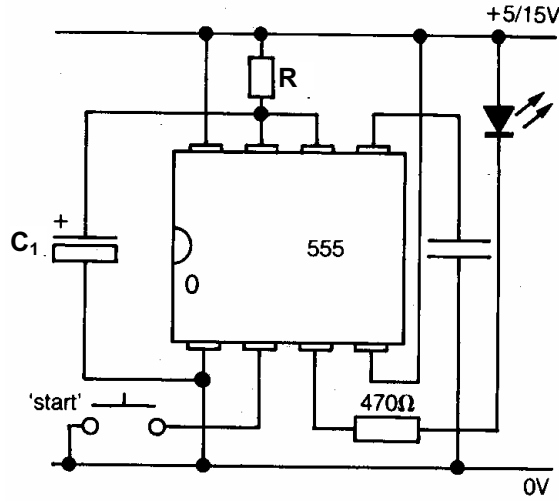

Fig. 5

(a) Describe, stage by stage, what happens when the start switch is pressed.

.....

.....

.....

.....

.....

.....

.....

..... [3]

(b) Explain how the value of the time delay is controlled.

.....

.....

.....

..... [2]

(c) Explain the purpose of the 470 Ω resistor.

.....

.....

..... [2]

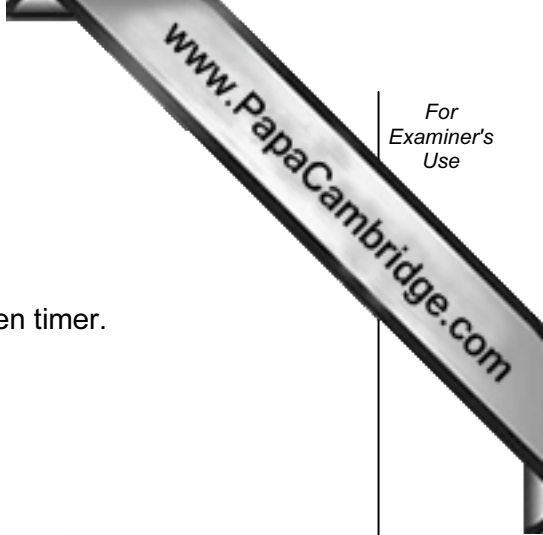

For Examiner's Use

(d) Name the type of switch used in this circuit and explain why it is the most suitable switch to use.

Name

Reason for selection:

.....

.....

..... [3]

(e) Fig. 6 shows a modification to the circuit.

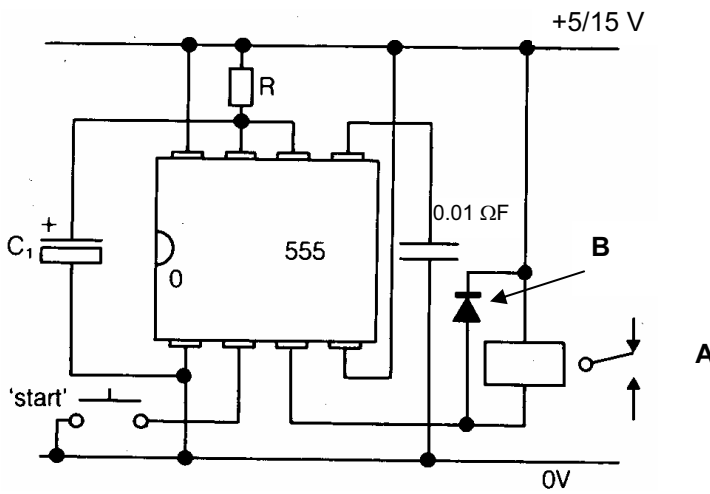

Fig. 6

Name and explain the purpose of:

(i) component A,

name [1]

purpose:

.....

..... [3]

(ii) component B.

name [1]

purpose:

.....

..... [2]

(f) Another method of controlling systems is to use logic circuits. Fig. 7 shows logic gate symbols and their truth tables.

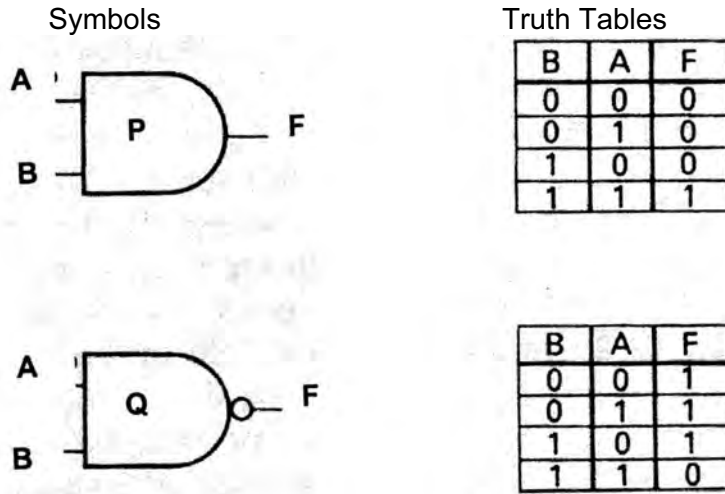

Fig. 7

(i) Name each logic gate.

P [1]

Q [1]

(ii) Draw a circuit diagram showing how logic gates could be used to control a four-digit code lock.

(iii) Give **one** other example of the use of logic gates to control a system. [3]

..... [1]

(iv) Describe **one** way of modelling a logic circuit before building it.

.....
.....
.....
.....

[2]

13 Fig. 8 shows a roof structure.

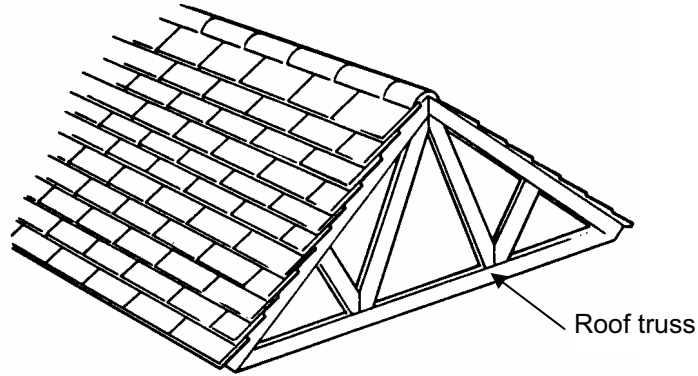

(a) The roof experiences static loading and dynamic loading. Explain the terms static loading and dynamic loading and give an example for each type of loading.

static loading: [2]

example: [1]

dynamic loading: [2]

example: [1]

(b) Explain why the roof truss is constructed in this way.

.....
.....
..... [2]

(c) Fig. 9 shows the loading on the truss.

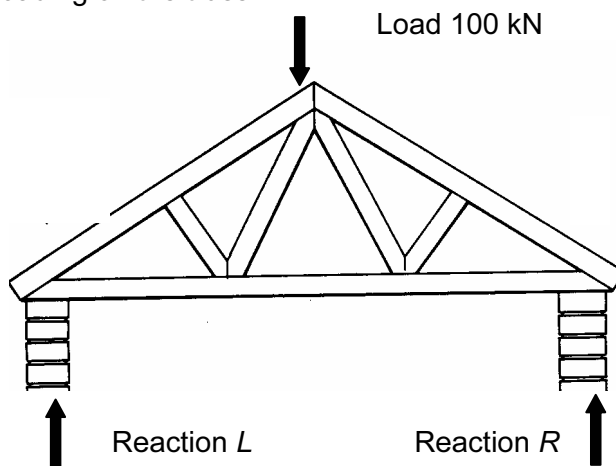

Determine the values of the reactions *L* and *R*.

[3]

- (d) It is decided to use a strain gauge to measure the deflection in the roof truss. Use sketches and notes to show how a strain gauge works.

[4]

- (e) Fig. 10 shows a doorway and lintel.

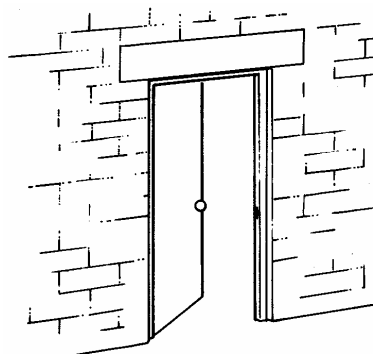

Fig. 10

An **I** section steel beam is used as the lintel.
Use sketches and notes to explain why this type of beam is used.

[3]

(f) Fig. 11 shows a stress/strain graph for mild steel.

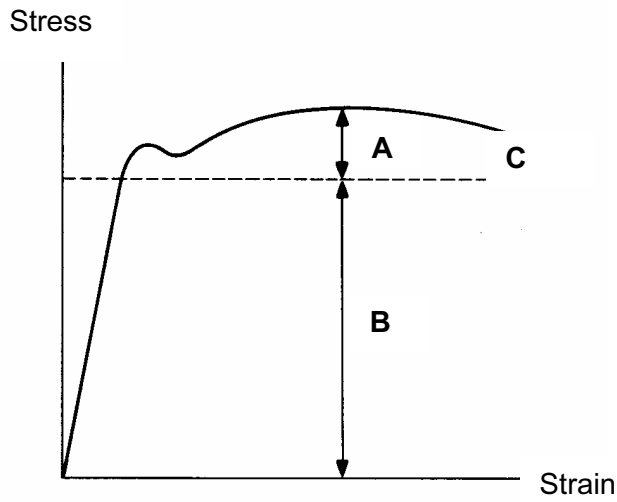

Fig. 11

(i) Name the features **A**, **B** and **C**.

- A** [1]
- B** [1]
- C** [1]

(ii) A mild steel test piece has a modulus of elasticity of 200 GN m^{-2} .
If the test piece experiences strain of 5×10^{-3} , calculate the value of the stress on the test piece.

[4]

14 Fig. 12 shows a pulley and belt drive system.

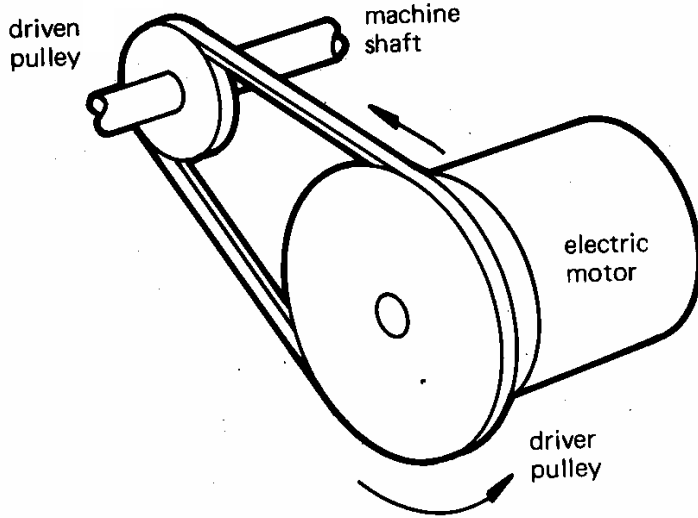

Fig. 12

(a) Explain the effect of this arrangement on the speed of the driven pulley.

.....
.....
..... [2]

(b) Explain the effect of this arrangement on the direction of rotation of the driven pulley.

.....
.....
..... [2]

(c) The diameter of the driven pulley is 20 mm and the diameter of the driver pulley is 40 mm. The speed of the driver pulley is 150 rpm. Calculate the speed of the driven pulley.

[3]

(d) Fig. 13 shows a stepped cone pulley system.

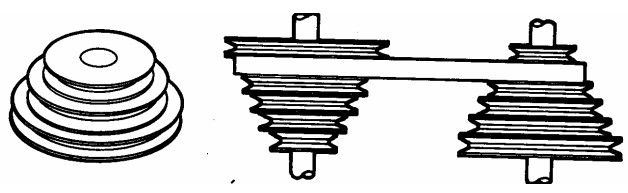

Fig. 13

(i) Give an example of a use for this type of system.

..... [1]

(ii) Explain why the pulleys and belts are V shaped.

.....
.....
..... [2]

(iii) Explain why the pulleys are arranged in this way.

.....
.....
.....
..... [3]

(e) Fig. 14 shows a winch mechanism.

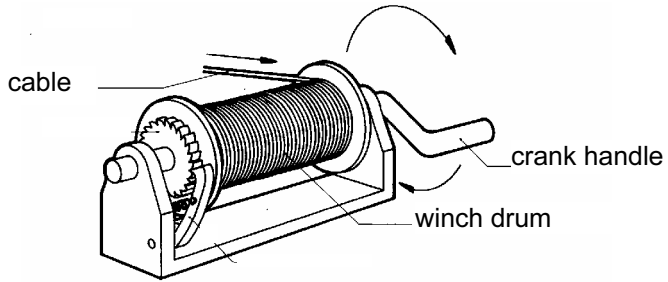

Fig. 14

The winch uses a ratchet and pawl to prevent the drum from unwinding.

(i) Add labels to Fig.14 to show the:

- ratchet,
 - pawl.
- [2]

(ii) Give one other example of the use of a ratchet and pawl.

..... [1]

(f) Fig. 15 shows a pear shaped cam and follower.

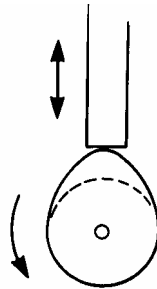

Fig. 15

(i) Add labels to Fig.15 to show how the system converts rotary motion to reciprocating motion. [2]

(ii) Give **one** application for this type of system.

..... [1]

(iii) During the rotation of the cam there is a dwell period.
Explain what is meant by the dwell period for a cam and follower system.

.....
.....
..... [3]

(iv) A crank and slider can be used to convert rotary motion to reciprocating motion.
Sketch and label a diagram of a crank and slider mechanism.

[3]